

# Explosionproof Rotating Beacons

## HAZARD•GARD® Series

Cl. I, Div. 1, Groups C, D  
Cl. I, Zone 1 and 2, Group IIB  
Cl. II, Div. 1, Groups E, F, G  
Class III

UL and cUL Listed  
NEMA 4X; IP66

**2S**

Eaton's Crouse-Hinds **Hazard•Gard EXR Series Explosionproof Rotating Beacons** are designed for installation in hazardous locations, such as manufacturing plants, heavy industrial facilities, refineries, chemical, petrochemical, pharmaceutical and offshore drilling platforms.

The units are UL Listed for Type 3R, 4X and marine installations. The rotating beacons are available for pendant, wall, stanchion and ceiling mounts, and come in six different globe colors.

The EXDR Series Explosionproof Rotating Beacon is diode polarized for use in standard 24–28V DC electrical circuits or in electrically supervised circuits. Electrically supervised circuits are typically used in life safety or security applications.

Under normal operation in an electrically supervised circuit, the diode is reversed biased, meaning it blocks voltage from being applied to the rotating beacon and prevents it from lighting. When a warning detecting device is activated, the diode's polarity is reversed through a circuit panel. The diode becomes forward biased, allowing voltage to the device and activating the rotating beacon.

### Applications:

- Security alert
- Equipment obstruction warning
- Obstacle warning
- Status indication of a process
- Areas under construction
- Supplement audible signaling or off limits

### Typical Industries:

- Utility gas plants
- Pharmaceutical plants
- Wastewater treatment plants
- Refineries
- Chemical plants
- Mining

### Features and Benefits:

- Powerful halogen rotating beacon emits bright light to provide critical visual warning
- Available in pendant, wall, stanchion and ceiling mount
- Available in six different globe colors—amber, blue, clear, green, magenta and red
- Beacon produces 75 rotations per minute
- Factory sealed—no external seals required
- Quick connect—strobe fixture threads onto mounting module for easy installation

### Certifications and Compliances:

- Class I, Division 1, Groups C, D
- Class II, Division 1, Groups E, F, G
- Class I, Zones 1 & 2, Group IIB
- Class III
- UL and cUL 1638, UL 1203 and UL 844 Listed
- 1598A Marine Listed
- NEMA 4X watertight, IP66



### Materials and Finishes:

- Body, mounting modules and guard—Copper-free aluminum
- Globe—Heat and impact-resistant glass
- Gaskets—Silicone
- External hardware—Stainless steel
- Internal components—Solid-state electronics in a moisture-resistant and heat-dissipating epoxy
- Epoxy powder coated for corrosion resistance

### Ratings:

- 120V AC (EXR) and 24–28V DC (EXDR)
- Operating Current: 0.382 amps at 120V AC  
0.8 amps at 24–28V DC
- Peak Candlepower: 3328 (EXR)  
2838 (EXDR)

### Hub Size:

- 3/4-inch NPT pendant, ceiling and wall mount
- 1 1/4-inch NPT stanchion mount

# 2S Explosionproof Rotating Beacons HAZARD•GARD® Series

Cl. I, Div. 1, Groups C, D  
Cl. I, Zone 1 and 2, Group IIB  
Cl. II, Div. 1, Groups E, F, G  
Class III

UL and cUL Listed  
NEMA 4X; IP66

## Ordering Information:

### Step 1 - Order Rotating Beacon Type

Cat. #	Voltage	Lens Color	NEMA Rating
<b>Explosionproof Rotating Beacons</b>			
EXR301A/120	120V AC	Amber	3R, 4X, Marine
EXR301B/120	120V AC	Blue	3R, 4X, Marine
EXR301C/120	120V AC	Clear	3R, 4X, Marine
EXR301G/120	120V AC	Green	3R, 4X, Marine
EXR301M/120	120V AC	Magenta	3R, 4X, Marine
EXR301R/120	120V AC	Red	3R, 4X, Marine
<b>Diode Polarized Explosionproof Rotating Beacons</b>			
EXDR301A/24 28	24–28V DC	Amber	3R, 4X, Marine
EXDR301B/24 28	24–28V DC	Blue	3R, 4X, Marine
EXDR301C/24 28	24–28V DC	Clear	3R, 4X, Marine
EXDR301G/24 28	24–28V DC	Green	3R, 4X, Marine
EXDR301M/24 28	24–28V DC	Magenta	3R, 4X, Marine
EXDR301R/24 28	24–28V DC	Red	3R, 4X, Marine

### Step 2 - Order Mounting Module

Cat. #	Hub Size	Mounting Style
EVMP2	3/4"	Pendant
EV22 & EV87	3/4"	Wall
EV22	3/4"	Ceiling
EVMJ4	1 1/4"	Stanchion

## Temperature Performance Data:

Description	Ambient Max. Temp.	Supply Wire	Class I, Div. 1, 2, Groups C, D Class I, Zone 1, Group IIB	Class II, Class III, Div. 1, Groups E, F, G	Class II, Class III, Div. 2, Groups F, G
EXR Series Rotating Beacon Voltage 120V AC	40°C	75°C	T6 (85°C)	T4A (120°C)	T4A (120°C)
	55°C	90°C	T5 (100°C)	T4 (135°C)	T4 (135°C)
	65°C	105°C	T5 (100°C)	T4 (135°C)	T4 (135°C)
EXR Series Rotating Beacon—Diode Polarized Voltage 24–28V DC	40°C	75°C	T6 (85°C)	T4A (120°C)	T4A (120°C)
	55°C	90°C	T6 (85°C)	T4 (135°C)	T4 (135°C)
	65°C	105°C	T6 (85°C)	T4 (135°C)	T4 (135°C)

# Explosionproof Rotating Beacons HAZARD•GARD® Series

Cl. I, Div. 1, Groups C, D  
Cl. I, Zone 1 and 2, Group IIB  
Cl. II, Div. 1, Groups E, F, G  
Class III

UL and cUL Listed  
NEMA 4X; IP66

**2S**

## Dimensions In Inches:

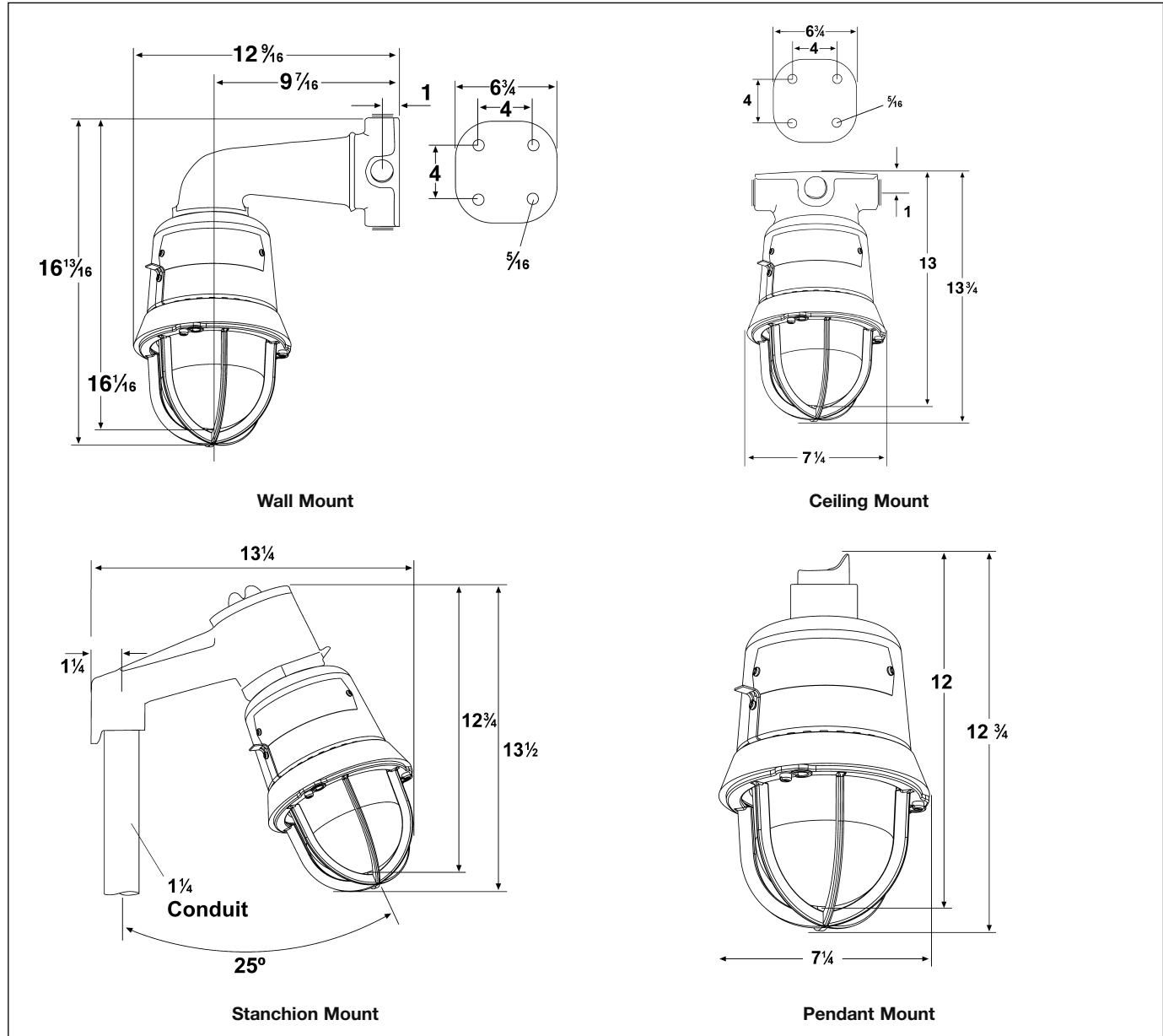

## Net Luminaire Weights:

Type	lbs.
Luminaire Housing with Guard	11.0

Type	lbs.
<b>Add mounting modules:</b>	
Pendant	1.0
Ceiling	1.0
Wall	4.5
Stanchion	2.5